

GUARDIAN VALUE RFID



Be-Tech GUARDIAN VALUE RFID is the latest addition to our range of security solution for the economical hospitality industry and community buildings.

Be-Tech GUARDIAN VALUE RFID is the ideal for budget hotel when replacing existing systems, it meets the needs of all budget hotels: from large chains to youth hotels businesses.

Be-Tech GUARDIAN VALUE RFID is equipped the most flexible platform for the future All-in-One card applications.

- RFID Specifications
- 13,56MHz technology
 - Compatible with the following standard:
 - ISO 14.443 A (MIFARE)
 - 11 free sectors for future All-in-one card application use

GUARDIANRFID BY BE-TECH BENEFITS:

- **More Guest Satisfaction:** Worldwide famous Mifare contactless technology for all guest and staff cards. No need to insert keycard, more easier to access guest room.
- **More Security:** Anti-hacker technology for locks. Unlike other competitor's keycards can be hacked into lock memory through mini USB port on outside escutcheon, crack and open the keycards. Be-Tech anti-hacker technology not allows re-program
- **FLASH RAM lock memory** from outside escutcheon.
- **More Adaptability:** RFID keycards and carriers can be use for any style hotels, you can choose from low cost guest card, wristbands and keyfobs
- to perfectly match different hotel type: Business, Resort, Spa, All-Inclusive.
- **More Information and Control:** GUARDIAN RFID electronic lock can check information on handheld Service Terminal for better information and management: Entry record audit trail, low battery status, real-time clock adjustment, etc...
- **More Integration:** You can integrate and interface GUARDIAN RFID keycards with other applications at your hotel.
- **More Exclusivity:** Provide a new experience for your customers and enhance the image of your hotel.
- **More Productiveness:** Provides Tour Group Reservation and Tour Group Check-in, enhance the check-in efficiency of your hotel.
- **...and Less Expense:** GUARDIAN RFID by Be-Tech is selling at a very reasonable price by Be-Tech global distributors.

FEATURES:

- Stand alone electronic lock with RFID technology.
- Operated with a completely sealed contactless module.
- High security stainless steel mortise lockcase available in ANSI, AUS and EURO versions.
- ROHS compliant.
- Stainless steel handle with high strength central spindle.
- 3-point stainless steel latch construction with antifriction mechanism.
- Mortise equipped 20mm throw high strength deadbolt.
- Mortise combined with DPR (Door Position Report) function for tracing and recording the door status and any openings with the mechanical override key.
- Panic release function – the deadbolt and latch are automatically retracted by inside handle for easy regress in emergency situation.
- ADA compliant (guest with physical disabilities).
- Future proof re-programmable FLASH RAM lock memory.
- Operated with a completely sealed contactless module.
- Powered by 4AA batteries that provide up to 1 year normal life time.
- 400 event audit trail.
- Compatible with BIS HOTEL software platform.
- High security mechanical override cylinder available.

A wide range of RFID (contactless) carriers

Be-Tech offers a wide range of RFID carriers which are designed for different applications (for your guests, for your staff or for your VIP guests) and gives you the opportunity to enhance your guests' experience at your hotel.

Typical hotel application:

- Guests: Reusable low cost guest keycards.
- Staff: Special printing long lasting staff keycards.
- VIP guests: Keyfobs and RFID Stickey for cell phones.

Typical resort & spa application:

- Guests: Wristband for guest convenience and all-inclusive.
- Staff: Special printing long lasting staff keycards.
- VIP guests: Wristbands or keyfobs.

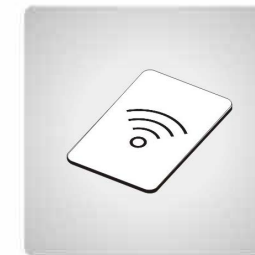

Reusable low cost guest keycards:
Cards may be customized at your request.



Special printing long lasting staff keycards:
Cards may be customized at your request.



Keyfobs:
Tags may be hang with a keychain, and can be customized at your request.



Wristbands:
The wristbands can be used for 'all-inclusive' resorts and spas.



RFID Stickey:
The ideal RFID carrier for global VIP guest's cell phones.





Dimensions:

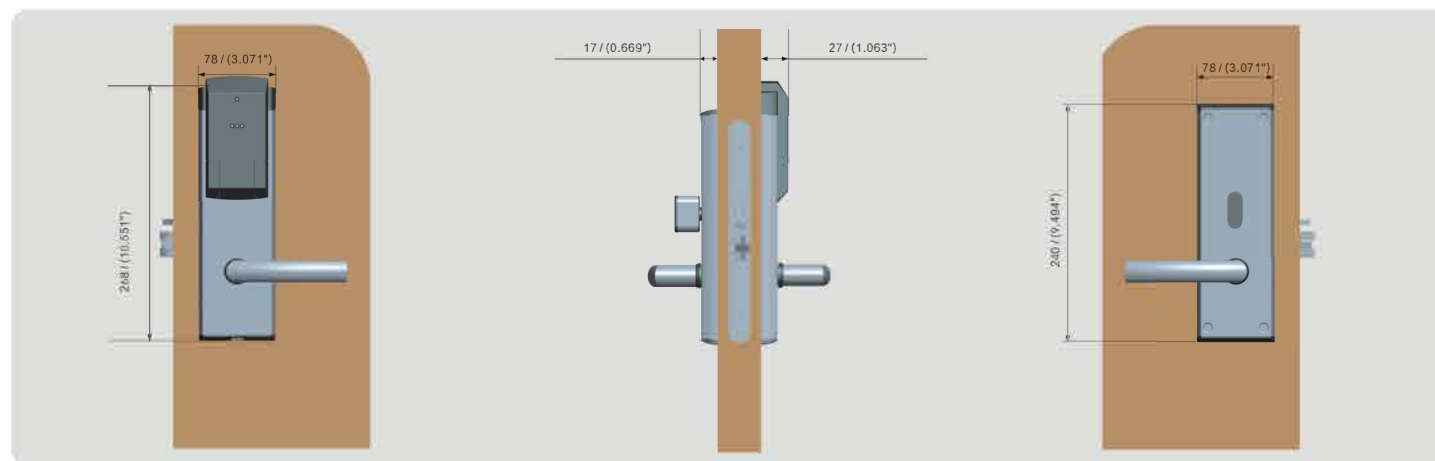

Emergency Cylinder

Be-Tech locks will also be supplied with mechanical override cylinder, enhance your hotel security level.

- Use of mechanical override will recorded in the memory for audit trail.
- Reset locks by swipe SID card (System Password Card) while turning mechanical key to override on cylinder.
- Superior pick resistance 6 pin high security cylinder and extended edition mechanical key for wide range door thickness installation.
- Mechanical cylinder will not visible with a plastic slide cover
- Cylinder is available for achieve mechanical key alike (KA) or mechanical key different (KD).



SPECIFICATIONS

ANSI lockcase

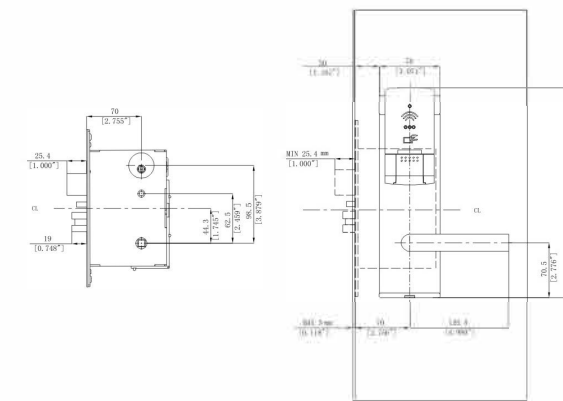

AUS lockcase

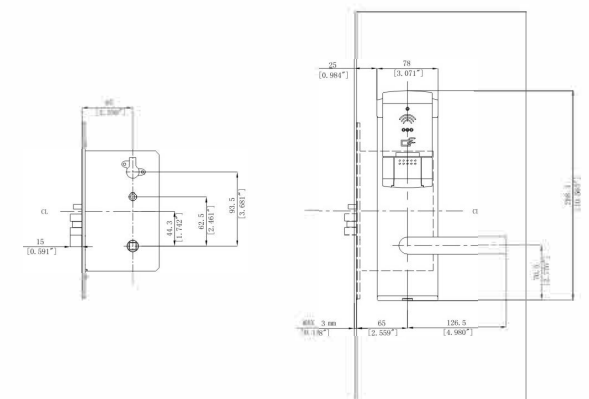

EURO lockcase

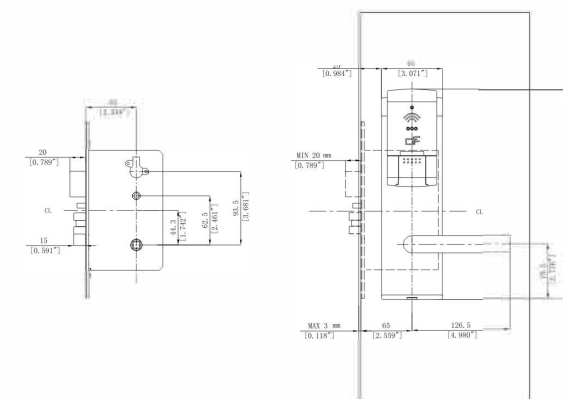

Suitable for the American , Suitable for the European and Pacific Ocean market

(ANSI):

- 28mm front Backset: 70mm

(AUS):

- 25.5mm front Backset: 65mm

EURO:

- 22mm front Backset: 65mm

Contact us:



+91 9980018277

Smart Your Life



Guangdong Be-Tech Security Systems Limited
 No.17, KeYuan 3 Road, Ronggui
 Shunde High-Tech Zone, Foshan,
 Guangdong 528306, P.R.China
 Tel: +86 757 28376123 | Fax: +86 757 28308823
 E-mail: export@be-tech.com.cn | www.be-tech.com.cn

Specifications may change without notice.